



Installation instructions

Bjelin Hardened Wood Flooring

woodura®

REINFORCED WOOD SURFACE TECHNOLOGY

The patented Woodura® surface technology is based on fusing a thin sheet of wood with a Compositex™ core through a powder mix layer. The powder mix perfectly fills up the natural openings of the wood and enhances the wood appearance. It also eliminates the need for wood-filler and creates a significantly stronger surface with a hardness three times greater than a traditional solid wood floor.



FOLD DOWN LOCKING SYSTEM

www.valinge.se

Installer/Owner Responsibility



We want you to have a pleasant experience installing our floors. All the **important safety information is in these instructions — read them carefully, follow the instructions correctly, and keep them somewhere safe.**

It's the responsibility of the installer and owner to make sure that the work-site, sub-floor, and sub-surface conditions meet or exceed the requirements detailed in these instructions. The manufacturer does not accept responsibility for installation problems or inadequate product performance resulting from a failure to meet these requirements.

All material needs to be carefully inspected for defects before installation — the warranty does not cover visible defects in material that has already been installed. Our flooring is manufactured in accordance with industry standards — allowing for manufacturing and natural deficiency tolerances of up to 5% of the total installation. To ensure you are satisfied with your product, it's important that you examine the color, finish, and style before the installation begins.

Wood is a natural product — and each piece is unique. Color, grain, and other characteristics naturally vary from plank to plank and are not covered under warranty. Remember to examine all material before installing and, if you're unsatisfied, do not install the flooring and, instead, contact your dealer asap as the flooring warranty does not cover visible defects after installation.

! Important information

Building regulations, recommendations, and working methods are revised frequently — always check your current local regulations regarding sub-floor preparation and underfloor heating with the official trade organisation, or a skilled craftsman, before starting your project.



Caution – Wood Dust

Cutting, sanding, or machining wood products produces wood dust.

Recommended precautionary measures:

- *Equipment should be equipped with a dust collector to reduce airborne wood dust.*
- *Wear an appropriate designated dust mask to reduce exposure to airborne wood dust.*
- *Avoid contact with eyes and skin.*
- *In case of irritation, flush eyes or skin with water for at least 15 minutes.*
- *In cases of severe irritation, seek immediate medical attention.*

Important precautionary safety measures:

- *Equipment should be equipped with a dust collector to reduce airborne wood dust.*
- *Wear an appropriate NIOSH designated dust mask to reduce exposure to airborne wood dust.*
- *Avoid contact with eyes and skin.*
- *In case of irritation, flush eyes or skin with water for at least 15 minutes.*
- *In cases of severe irritation, seek immediate medical attention.*

Table of content

Pre-Installation & Jobsite Conditions	
Important	4
Fixtures and fittings	4
End joints	4
Door openings.....	4
Skirting boards	5
Expansion gaps	5
Skirting board thickness	6
How to calculate the skirting board thickness	6
Minimum skirting board thickness for various floor widths	6
Subfloor	7
Vapour barrier.....	7
Underlayment.....	8
Underfloor heating.....	8
Room climate.....	8
Full surface bonding	8
Preparations	
Check-list	9
Tools & Equipment	9
Floating floor Installation	
Long and short side locking techniques	10
When angling is not possible	12
Reverse installation	12
Installation around pipes/tubes	12
Dismantling of an installed plank	
Dismantle installed planks	13
How to use the dismantling pin	13
Looking after the floor	
Floor treatment after installation	14
Cleaning	14
Maintenance.....	14

Pre-Installation & Jobsite Conditions

Important information

Carefully read all the instructions *before* you begin the floor installation.

- Välinge Hardened Wood Floors can be installed in most places in the home and commercial areas. They are not suitable for — and should not be installed in — humid or wet areas such as bathrooms or saunas.
- Välinge Hardened Wood Floors can be installed over most hard surfaces, including resilient floor coverings such as LVT, SPC, VCT. For installations over linoleum ensure that it is properly glued down, fixed, completely level, and has no loose areas.

❗ Important information — do not install over soft surfaces

- Instructions for transport and storage, indoor climate, and final preparation
- Packages should be transported and stored horizontally — acclimatise unopened packages in a dry, well-ventilated area of the job site for at least 48 hours before installation.
- Maintain a room temperature of at least 18°C (64°F) and relative air humidity (RH) range between 35-65% during storage and installation.
- Only open the packages when you have started installation.
- Floor panels from several different packages can be mixed to get your preferred look.
- Examine each floor panel in daylight *before installation* to look for any damage or visible defects in color or texture. Problems with defects need to be brought to the attention of the supplier *before installation*.
- Use protective paper without a polymer layer on top of the floor during installation.
- Do not attach any adhesive tape to the floor.
- As the buyer, you are responsible for approving the product — even if it is installed by a professional installer. If the product is installed, it is seen to have been approved.
- The maximum floor width is 25 linear meters (80 linear ft) in either direction before a transition is required.
- In all areas bigger than 625m² (6727 ft²) an expansion joint is essential to avoid gaps appearing in the joints due to changes in humidity and temperature.

Fixtures and fittings

- Never fix or bolt any kitchen units, fittings, or partitions to a floating floor — it will prevent expansion and contraction that occurs with seasonal changes and humidity. Instead, fix any fitting to the sub-floor first and then install the floating floor around them, leaving the appropriate space as an expansion gap.
- Modern kitchen units are usually fixed to the wall with support legs resting on the floor at the front of the units — this is generally ok for the floor. The exception is kitchens with heavy worktops such as marble or granite — where the support legs should not rest on the floor as it can restrict the expansion and contraction. As an alternative, chipboard of the same thickness as the floor can be installed under kitchen units.
- It is ok to install the floor under the fridge, freezer, and dishwasher — always ensure that they are placed on plastic drip trays to avoid unseen leaks.
- If the kitchen contains a wood-burning stove or similar, install chipboard or similar under the heat-resistant floor plate or hearth under the stove. The heavy stove rests on the chipboard and not the floor, preventing problems with expansion and contraction. The chipboard should be slightly smaller in dimensions of the hearth to act as an expansion gap when you install the floor around the stove. It will also make it easier to replace floor panels near the stove, if necessary.

End joints

- The floor needs to always be installed staggered, even in small areas — not only does this look better, but it's also essential for structural stability.
- Staggered end joints mean that no two adjacent end joints are aligned or close to each other — they should be staggered by at least 400 mm (16") to prevent any gaps or other structural problems occurring.

Door openings

- When installing the floor through a door or archway, always divide the floor with an expansion gap and cover that with a threshold or moulding.
- If there is an existing threshold that is fixed to the sub-floor, leave expansion gaps on either side of it. Alternatively, remove the existing threshold, install the floor, and replace the threshold — leaving an expansion gap underneath it.
- If the threshold or moulding is too high for the door to open and close freely after installing the floor, the door can be sanded or cut to fit.
- It may be possible to install the floor through door openings or arches without using a threshold or expansion gap, however, this type of installation requires a skilled professional.

Skirting boards

- Never attach the skirting boards directly to the floor as it can restrict the expansion and contraction and cause structural problems.
- Attach the skirting boards to the wall instead — using nails, screws, or adhesive.
- Mitre joints are recommended for the best results.
- The width of the expansion gap decides the thickness of the skirting board and not vice versa.
- Read the skirting board thickness section for more details.

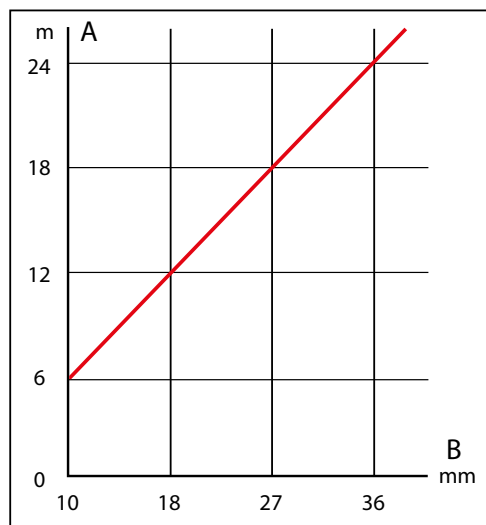

Graph shows: A wood floor's movements as it absorbs and emits moisture.

Expansion gaps

- Wood floors expand and contract due to temperature and seasonal changes. This is why an expansion gap is critical when you install near walls and other fixed objects — every edge needs an expansion gap between it and the floor.
- The floor needs to be able to expand at thresholds, door frames, pipes, pillars, stairs, tiles, other wooden flooring, etc.
- The floor will also contract in the winter, so the width of the skirting board needs to take this contraction into account.
- Remember that an expansion gap between two rooms or floor areas will be double the width of the expansion gap between the floor and a fixed object — such as a wall. This is because both floor areas need space to expand and contract.
- A room's RH (relative air humidity) value changes due to seasons and the floor needs to be able to expand and contract within this range.
- Calculate the width of the expansion gap by using the formula: $1.5\text{mm} \times \text{the room's width in meters} = \text{B mm}$
In the illustration below: $1.5\text{mm} \times \text{A meters} = \text{B mm}$
- **For example:** a room that is 4 meters (13.1 ft) wide needs a 6mm (0.24 inch) expansion gap. Calculated as follows: $1.5\text{mm} \times 4 = 6\text{mm}$ (0.24 inch)
- As a rule of thumb, an expansion gap between 8—10mm (5/16—3/8") can be used for rooms less than 6 meters (19.7 ft) wide.

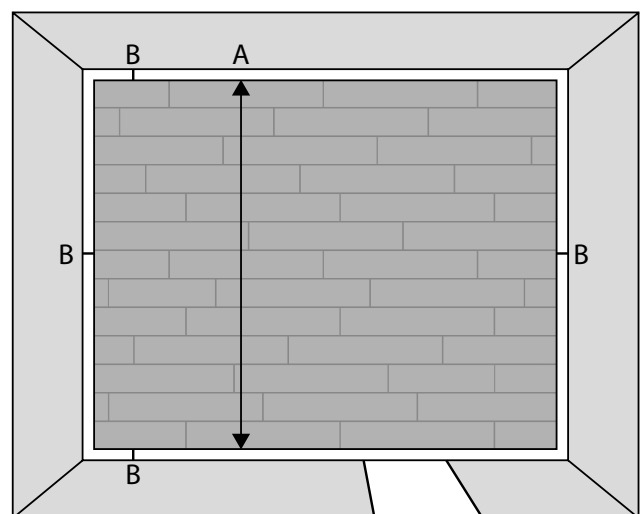

Skirting board thickness

- Remember that the width of the expansion gap decides the thickness of the skirting board and not vice versa.
- Larger floor areas will need a bigger expansion gap, which means that a thicker skirting board will also be needed.

Top Tip: If you're building new or renovating, one simple way to avoid overly thick skirting boards is to leave a gap between the plasterboards on the wall and the sub-floor. This will allow you to use the thickness of the plasterboard in your expansion gap measurement and will require a much thinner skirting board — as shown below in illustration B.

How to calculate the skirting board thickness

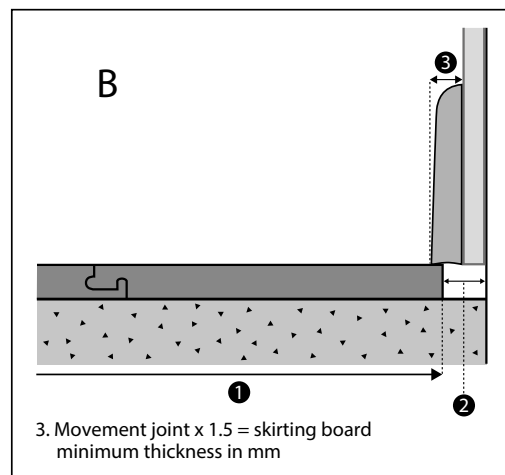
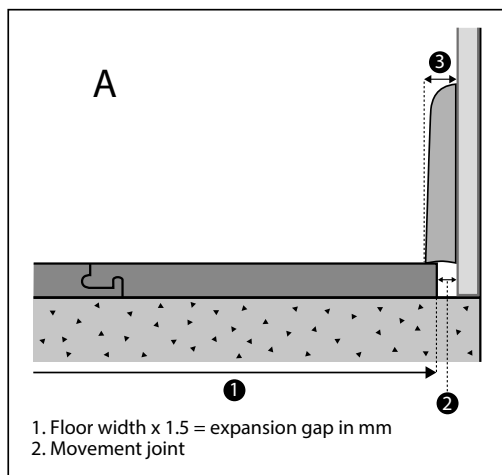

Make sure that the floor does not go under the wall panel, e.g. plasterboard.

Minimum skirting board thickness for various floor widths

Floor width 1	Movement joint 2	Cover allowance	Skirting thickness 3
4 m (13,1 ft)	6 mm (0,24 in)	3 mm (0,12 in)	15 mm* (0,59 in)
6 m (19,7 ft)	9 mm (0,35 in)	5 mm (0,20 in)	15 mm* (0,59 in)
8 m (26,2 ft)	12 mm (0,47 in)	6 mm (0,24 in)	18mm* (0,71 in)
10 m (32,8 ft)	15 mm (0,59 in)	7 mm (0,28 in)	22 mm* (0,87 in)
12 m (39,4 ft)	18 mm (0,71 in)	9 mm (0,35 in)	27 mm* (1,06 in)
15 m (49,2 ft)	22 mm (0,87 in)	11 mm (0,43 in)	33 mm (1,3 in)
18 m (59,0 ft)	27 mm (1,06 in)	13 mm (0,51 in)	40 mm (1,56 in)

* Because a minimum of 8-10 mm (5/16 - 3/8") movement joint is recommended.

Subfloor

- Hardened wood floors can be installed on almost any type of subfloor — for example, wooden or cement concrete floors.
- Make sure the sub-floor is level, flat, dry, and clean.
- Any unevenness in height greater than 3mm (1/16") over a length of 2 meters (6 ft) needs to be levelled — use patching or levelling compound or ground/sand the area.
- Wood subfloors must have a moisture content (MC) less than 13% at 20°C (68°F).
- Concrete or slab subfloors must have a maximum relative humidity (RH) of 80% RH at 68°F.

ⓘ Important information — a vapor barrier needs to be installed. The vapour barrier needs to be at least 0.2mm thick, age-resistant pe-foil.

Vapour barrier

A vapour barrier (PE - foil) is obligatory on the following types of structural floor, irrespective of age.

- Ground-supported floors
- Structural floors situated above warm or humid areas, such as boiler or laundry rooms
- Floors above a crawl space foundation
- Warm floors, such as floors with underfloor heating
- Lightweight concrete floor structures

Lightweight concrete floor structures require a long time to dry out and must be fitted with a vapour barrier.

All types of concrete subfloor and ceramic require a vapour barrier, even if the floor construction includes damp protection.

The foil needs a 20cm overlap between the joints and needs to be taped and folded up at each wall. Once the skirting boards are installed, the retarder will be trimmed to fit.

A ventilated moisture barrier — for example, from manufacturers like Platon and Matakı — is recommended if there is a risk of additional moisture or the RH in the subfloor is over 90% and needs to be installed following the manufacturer's instructions.

- Hardened wood floors installed on this type of substrate require a load distribution board — such as masonite, plywood, or chipboard — with a minimum thickness of 6 mm (0,24") on top of the moisture barrier.

The vapour barrier needs to be at least 0,20 mm thick, age resistant PE-foil. The foil should be at least 20 cm overlap between the joints, taped, folded up against the walls and will be cut after floor skirtings are installed. If there is a risk of additional moisture or the RH in the substrate is over 90%, we recommend a ventilated moisture barrier, a plastic sheeting vapour barrier (PE-foil) does not give sufficient protection against moisture. Ventilated moisture barrier are made by a number of manufacturers, e.g. Platon and Matakı, and must be installed in accordance with the manufacturers instructions. When installing Välinge Hardened Wood Floor on this type of substrate, a load-bearing profiled (i.e. tongue/groove)masonite, plywood or chipboard in at least 6 mm (0,24") thickness must be installed on top of the ventilated moisture barrier.

Underlayment

- Installing an approx 2mm thick underlayment is recommended for noise reduction.
- An underlayment material with a compressive strength of at least 60 kPa is recommended.
- The underlayment must be installed on top of the vapour barrier.

⚠ Important information — Certain PE-foils are laminated to an underlying foam, such as Combifoam or similar.

Underfloor heating

- Hardened wood floors can be installed on water-based or electrical floor heating systems.
- The floor heating system must be flat and distributed evenly in the subfloor.
- A room sensor (thermostat) and a floor sensor (for maximum temperature limitation) must be installed to prevent the surface temperature from exceeding 80°F (26°C).
- Underfloor heating must never be installed under kitchen units or similar installations.
- For water-based floor heating systems with the pipes positioned in profiled particle floorboards, covering with heat-distributing aluminum sheets and a 6 mm (0,24") load-bearing profiled — for example, tongue/groove — particleboard or plywood is recommended

⚠ Important information — all floor heating systems require a pe-foil vapour barrier between it and the underlay material of the subfloor.

Room climate

- Ambient climate for wood floors should be 35-65% relative air humidity (RH) at 20°C (68°F).
- A low RH can cause small cracks to appear in the joints between the planks.
- An indoor air conditioner for temperature and vapour is the optimal way to control the room — especially during the winter.
- Complaints regarding unevenness, joint openings, or board size cannot be inspected if the room climate RH and temperature are outside the limits — it can be inspected only after the room climate has had normal values for at least 4 weeks.
- Wood is hygroscopic — meaning that it absorbs moisture — and is affected by fluctuations in the room climate RH and temperature. The changes normally resolve once the room climate returns to the recommended levels.
- Underfloor heating will cause increased shrinkage in a wood floor due to the drying effect. During winter, humidifiers are recommended.

Full surface bonding

- As an alternative to a floating installation, Hardened Wood floors can be installed with full-surface bonding using an approved adhesive.
- All floor installation instructions and adhesive manufacturers' instructions must be followed carefully when installing floors with full surface bonding.

Recommended full surface bonding products:

- **Bona:** Bona Titan — plus Bona R590 when a moisture barrier is also required.
- **Bostik:** Bostik Maxi Bond Parquette — contact Bostik technical support when a moisture barrier is also required.

Both these products are an elastic 1-component silane adhesive for wooden floors.

Recommendations for adhesives are based on extensive testing by the manufacturers. Test the adhesive carefully before installing flooring or contact the adhesive manufacturer's technical customer service if you have any questions.

⚠ Important information — we do not assume liability or accept warranty claims for any losses incurred by using an adhesive incorrectly.

📖 For more information about full surface bonding, please read: Installation instructions glue down Hardened wood floors at www.valingeflooring.com

Final preparations



Check-list:

- Remove the old skirting boards
- Remove or trim existing door casings before installing the floor
- Inspect the planks for color, finish, milling, and grade
- Remove any damaged planks
- Leave the correct expansion gap (calculated on page 5) between the floor and all fixed structural elements such as walls, thresholds, pillars, or pipes
- Measure the room and calculate the number of rows required
- Choose the installation direction to suit the room's proportions — as a general rule, lay the floor in the same direction as the main light source



Recommended tools and equipment:

- Safety glasses
- NIOSH approved Dust Mask
- Vacuum cleaner
- ½ inch Spacers (see table for gap distance)
- Sliding miter saw, jigsaw, laminate flooring guillotine (such as Mega STRATICUT 400), or hand saw
- Metal or Diamond Saw Blade
- Fine pencil
- Tape measure
- Set square 45° & 90°
- Moisture Meter
- PE Film (Floating)
- White glue (D3) for adjustment at radiator pipes

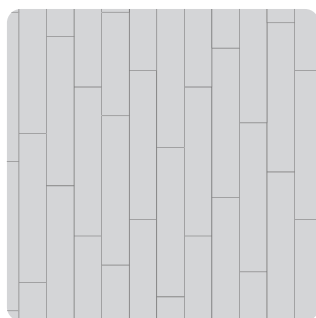
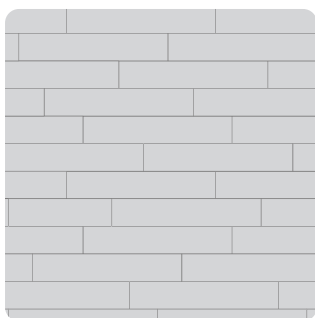

Floating floor installation

Long and short side locking techniques

The **long sides** of the planks are connected by angling the tongue into the groove — where the lower lip has a locking design. The **short sides** of the planks are connected with Välinge Innovation's patented 5G® Fold Down™ locking system and simply fold down — locking with a reassuring “click”.

📺 Visit www.valingeflooring.com/downloads for video instructions

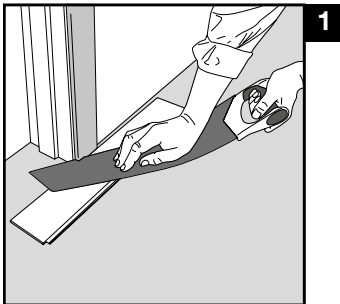

Door frames can be removed and raised, but it's usually easier to cut them. Use a loose plank as a template and saw off the excess. Ensure that the floor is not pressed between the subfloor and the door frame.

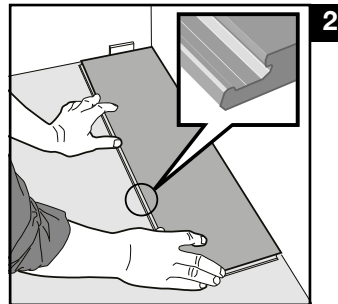

Now it's time to lay the first plank in the first row. Start in a left corner and lay a plank with the tongue side facing the wall. Now insert a wedge between the wall and the plank's left short side so there is a gap at least ½" (8-10mm) wide.

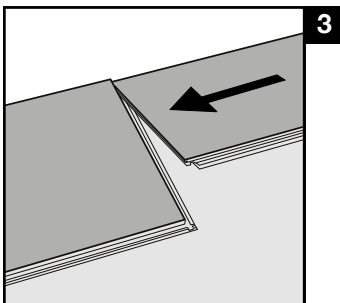

Position the second plank to the right short side of the first plank.

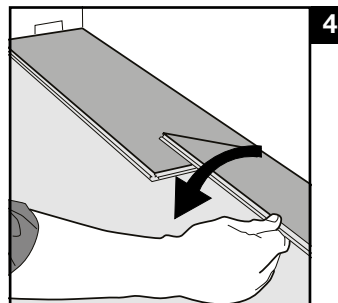

Fold down the second plank, making sure it's positioned tightly to the first plank — press down firmly and listen for the click that means it's locked in place.

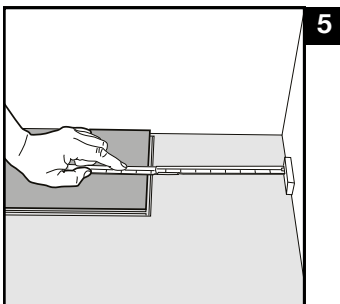

Continue installing the first row. When you are close to the wall on the right side, place a wedge at the wall and measure the length to determine the size of the row's last plank.

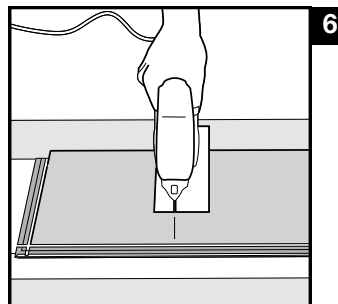

Cut the row's last plank to size. If you are using a jigsaw, cut it face down. If you are using a hand saw, cut it face up.

Installation instructions

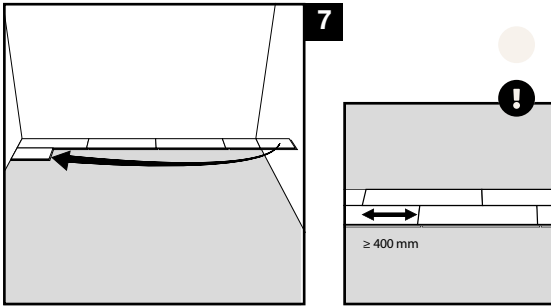

To begin the second row, use the remainder of the cut plank you used to finish the first row.

! *Important information — the offset between the short-side joints in parallel planks from the first and second rows must be at least 400 mm.*

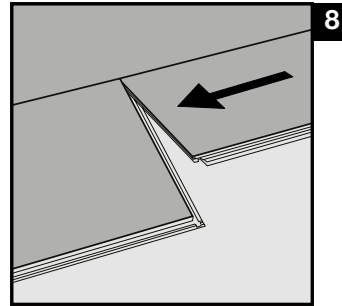

Position the second plank to the right short side of the first plank.

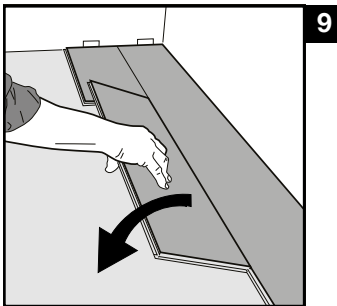

Fold down the second plank, making sure it's positioned tightly to the first plank — press down firmly and listen for the click that means it's locked in place.

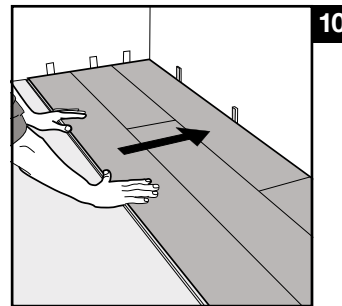

Continue to install the row as before. When you have completed 2–3 rows insert wedges between the wall and the first row so there is a gap at least 8-10mm (½”) wide.

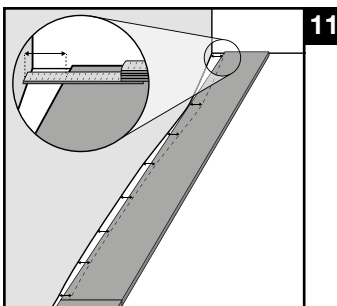

The first and last row may need to be adjusted if the wall is uneven. To achieve this, trace the wall profile to the first or last plank, cut, and install.

Installation instructions

When angling is not possible

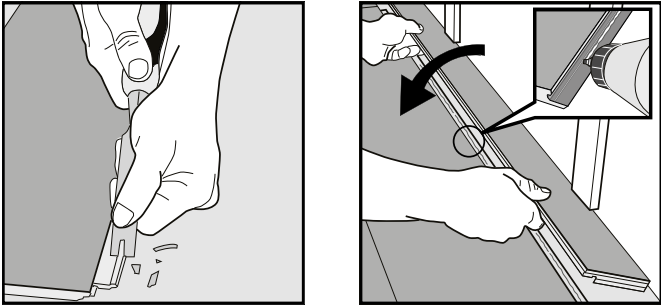

Remove the locking element/hook as shown in the diagram. Use white PVAc glue to connect the planks. Press/place wedges between the glued strip and the wall.

Reverse installation

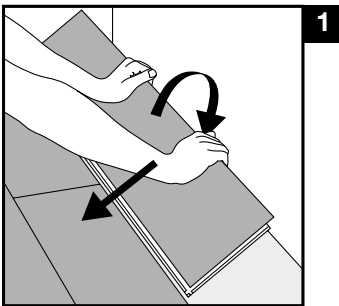

When installing in reverse, start from the left. Angle the long side groove into position at the tongue of the adjacent plank from the previous row and fold down to lock into place.

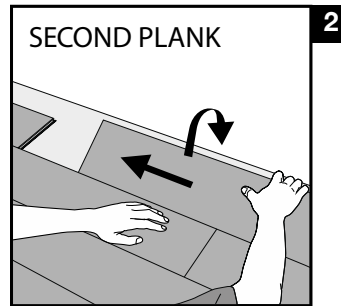

Angle the long side groove of the second plank into position at the tongue of the adjacent plank from the previous row and fold down. Now slide the second plank to the left to position it to the right short side of the first plank. Press down firmly and listen for the click that means it's locked in place.

Installation around pipes/ tubes

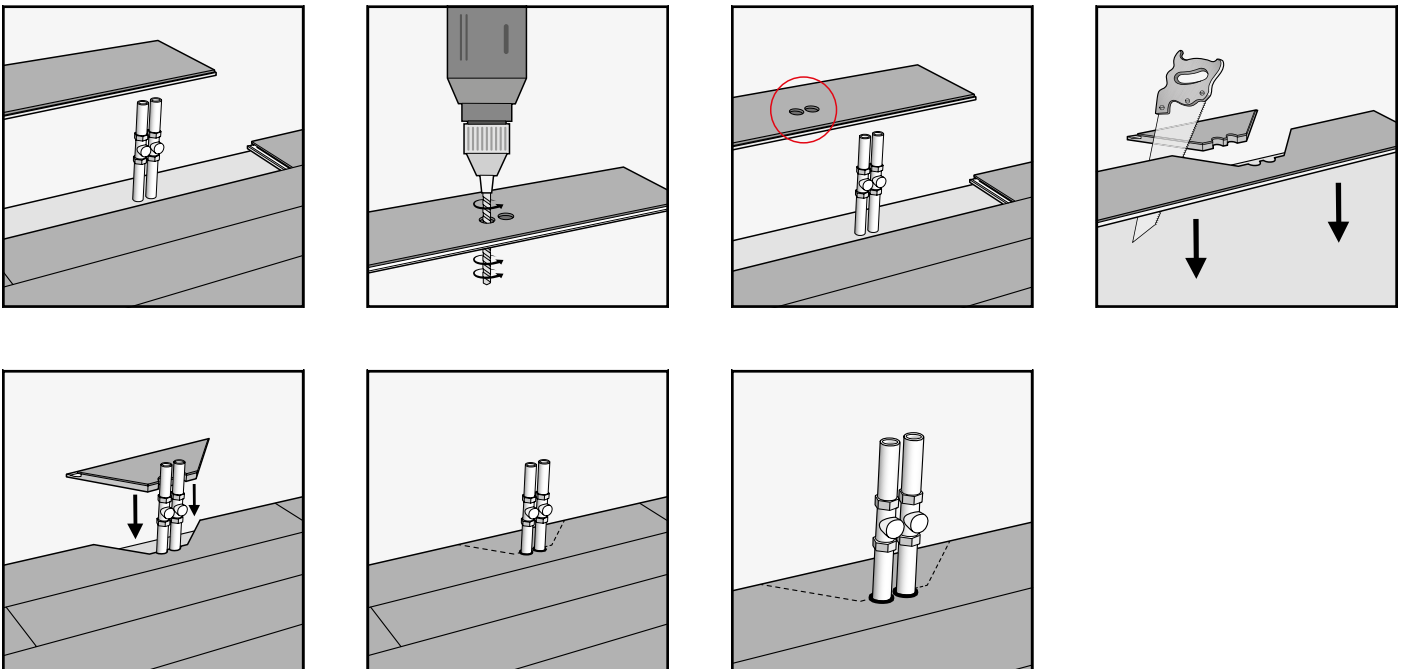

Mark the center point of the pipes on the plank. If the required expansion gap is 10mm, drill holes 20mm bigger than the pipe diameter. Cut as shown in the illustration. Apply white glue and install the floor pieces. Cover the holes with pipe collars or fill with a joint sealer.

Dismantling of an installed plank

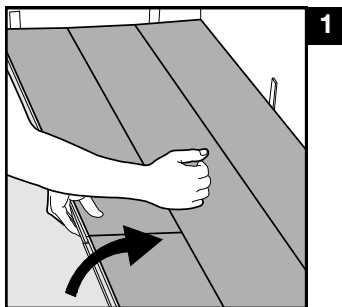

When a plank is locked, it is not possible to dismantle it by hand. Lifting up and knocking gently on a plank will unlock the row — fold up to fully release the long side.

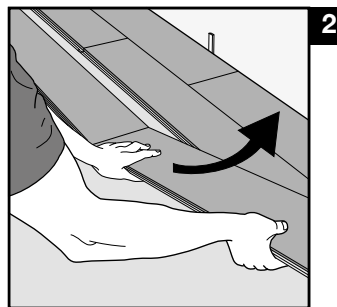

Once the whole long side is released each plank can be dismantled by angling the short sides up vertically.

Using the dismantling pin

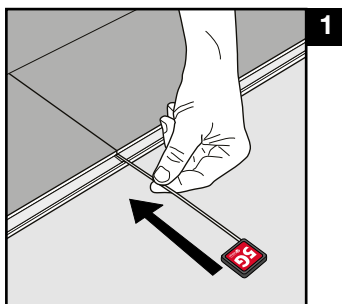

Position the dismantling pin into the gap between the tongue and groove on the short end of the plank. Push the dismantling tool into the short side.

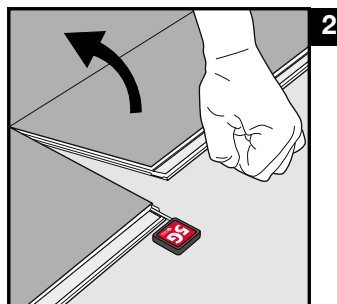

The short side should now be unlocked and the plank can be lifted.

Looking after the floor

- Once the floor is installed, it is not recommended to place carpets on the floor for the first few months.
- If the floor has lighter colors from rugs or other covering, it will change color quickly when they are exposed to daylight.
- Use protective pads on the base of furniture legs and protective mats under caster chairs with hard wheels.
- Always use a protective mat at entrances.

Floor treatment after installation

Pre-lacquered Hardened Wood floors do not need any surface treatment after installation. Cleaning the floor before use is recommended — use a hardwood floor cleaner for lacquered floors, such as Bona Hardwood Floor Cleaner.

! *Important information — always use a detergent specifically for uv acrylic wear layer hardwood floors. Normal soap can leave a fat residue on the floor surface — making it difficult to clean.*

Pre-oiled Hardened Wood floors in homes do not need any surface treatment after installation. Cleaning the floor before use is recommended — use a hardwood floor cleaner for oiled wood floors, such as Bona Hardwood Floor Cleaner.

! *Important information — always use a detergent specifically for oiled hardwood floors. Normal soap can leave a fat residue on the floor surface — making it difficult to clean.*

! *Important information — in commercial and high-traffic areas should receive additional surface treatment immediately following installation.*

1. CLEAN THE FLOOR AND MAKE SURE IT IS DUST FREE
2. TREAT THE FLOOR WITH A HARDWAX OIL FROM OSMO

Regular cleaning

- “Dry” cleaning is recommended to keep the floor clean on a day-to-day basis — use a vacuum cleaner, dust, or microfibre mop.
- Dirt and stains can be removed easily with a magic melanin sponge.

Deep Cleaning

1. Clean the surface with a microfiber cleaning pad
2. Wash the floor with a hardwood floor cleaner for lacquered floors, such as Bona Hardwood Floor Cleaner.

Maintenance

Pre-lacquered Hardened Wood floor

When needed, a hardwood floor refresher for lacquered wooden floors, such as Bona Hardwood Floor Refresher, can be used to freshen up the surface and remove micro-scratches.

A floor refresher is suitable for restoring a worn lacquer — giving a protective layer for easier cleaning and maintenance. It is not, however, a substitute for a refinish.

! *Important information — using a hardwood floor refresher will make a lacquered floors gloss value increase. The more used, the higher glossier it will become and it will more noticeable on a matt lacquered floor. Make sure that the floor is clean from polish, wax, and grease stains before applying the refresher.*

Pre-oiled Hardened Wood floor

Pre-oiled floors should be maintained regularly using a maintenance oil or hardware oil from Osmo.



woodura®



The Woodura® and 5G® Dry™ logos are registered trademarks owned by Valinge Innovation AB and any use of such marks are under license.