



---

Installation instructions – Glue Down

# Bjelin Hardened Wood Flooring

---

woodura®

REINFORCED WOOD SURFACE TECHNOLOGY

The patented Woodura® surface technology is composed of a thin sheet of wood fused with a Compositex™ core through a powder layer. The powder mix perfectly fills any natural gaps in the wood and enhances the appearance. It also eliminates the need for wood filler and creates a significantly stronger surface with a hardness three times greater than a traditional solid wood floor.



LOCKING SYSTEMS

[www.valinge.se](http://www.valinge.se)

## Installer/owner responsibility



It is extremely important that you read and understand this information completely prior to starting, since improper installation can void the warranties. It is the responsibility of the installer and owner to ensure that the job site environment, subfloor and subsurface conditions involved meet or exceed all requirements as outlined in these installation instructions. The manufacturer declines all responsibility for product performance or installation failure should these environmental conditions not be met.

Inspect ALL material carefully for defects prior to installation. Material installed with visible defects is not covered under warranty. Flooring is manufactured in accordance with industry standards, which allows manufacturing and natural deficiency tolerances up to 5% of the total installation. Examine the flooring for colour, finish and style before installation to ensure you have the correct product.

Wood is a natural product that can vary in colour, grain and natural characteristics from plank to plank and is to be expected. We do not warrant against these natural variations from plank to plank. If not satisfied with the flooring prior to installation, contact your dealer. DO NOT install the flooring.

Accepting or rejecting the material must be done prior to installation. Flooring warranties DO NOT cover materials with visible defects once they are installed.

### **📌 Important information**

*Building rules, recommendations and working methods are constantly updated. Therefore, always check the current local regulations about sub-floor preparation and underfloor heating with the appropriate trade organisation or skilled craftsman before starting your project.*



### **Caution – wood dust**

*Cutting, sanding or machining wood products produces wood dust.*

***Precautionary measures:** Equipment should be equipped with a dust collector to reduce airborne wood dust. Wear a suitable dust mask to reduce exposure to airborne wood dust. Avoid contact with eyes and skin. In case of irritation, flush eyes or skin with water for at least 15 minutes. In cases of severe irritation, seek immediate medical attention.*

# Table of contents

<b>Pre-Installation &amp; Job Site Conditions</b>	
Important.....	4
Subfloor .....	4
Damp-proof membrane .....	4
Underfloor heating .....	5
Room climate .....	5
Glue down installation .....	5
Recommended products .....	5
<b>Preparations</b>	
Checklist .....	6
Tools & equipment needed .....	6
<b>Installation instruction</b>	
Layout .....	7
Installation .....	7
Subsequent rows .....	9
When angling is not possible .....	10
Installation around pipes .....	10
<b>After installation</b>	
Installation treatment .....	11
Daily cleaning .....	11
Regular maintenance .....	11

## Pre-installation & job site conditions

### Important

***Read through the entire glue down installation instructions carefully before you begin to install the floor.***

- Välinge Hardened Wood Flooring can be installed in all indoor areas and in most commercial premises, but is not suitable for installation in humid/wet areas (bathrooms, saunas, etc).
- Transport and store the cartons horizontally. Unopened cartons should be acclimatised at the job site in a dry, well-ventilated area for a minimum of 48 hours.
- During storage and installation, maintain a room temperature of at least 18°C and a relative air humidity (RH) range of 35-65%.
- Open the packages only when you begin installing the floor.
- Mix planks from several packages before installation, in order to achieve the desired floor pattern.
- Check all planks in daylight before installation for recognisable faults in colour and texture.
- Place a protective paper, without a polymer layer, over the floor surface during the installation.
- ***Please note that no tape should be attached to the floor.***
- All concerns regarding deviations on the product should be discussed with the supplier before installation.
- When a product is installed either by yourself or a skilled craftsman, you as a buyer are considered to have approved the product.
- Any installed plank is an approved product.

### Subfloor

Välinge Hardened Wood Flooring can be glued to any professionally installed subfloor. This includes concrete and screed, as well as chipboard or plywood boards.

Ensure that subfloor is level, flat, dry and clean. Any deflection in the subfloor greater than 3 mm over 2 meters length should either be smoothed with patching or a levelling compound or ground/sanded down mechanically.

#### **Concrete/slab subfloors:**

The surface temperature of the subfloor should be a minimum of 15°C.

- Subfloors of concrete should have max 85% relative humidity (RH) at 20°C.

#### **Wood subfloors:**

Prepare the subfloor for installation, re-nail any loose areas that are squeaky. Sand or plane any raised areas and fill any low areas.

- The moisture content of wood subfloors must be less than 10% Moisture Content (MC) at 20°C.

#### **Damp-proof membrane:**

A traditional damp-proof membrane (PE - foil) cannot normally be laid when the wood floor is going to be glued to the subfloor.

If damp is suspected in the subfloor, use a recommended adhesive and primer (see the Gluing section).

Alternatively, lay 0.2 mm sheeting (PE - foil) onto the concrete floor and then a loadbearing profiled (i.e. tongue/groove) particleboard or plywood of at least 12 mm thickness on top. The wood floor can then be glued to the particleboard or plywood.

After any necessary improvements have been made to the subfloor the Hardened Wood Flooring is ready for installation in accordance with the appropriate standards and technical specifications.

**! Note!** Always check the current regulations with the appropriate trade organisation in your country before starting your project.

### Underfloor heating

Välinge Hardened Wood Flooring can be installed on water-based or electric floor heating systems. The underfloor heating system must be flat and well distributed in the subfloor. Both a room sensor (thermostat) and a floor sensor (for maximum temperature limitation) must be installed to prevent the surface temperature from exceeding 27°C.

Underfloor heating must never be installed under kitchen cupboards or similar installations.

Water-based floor heating systems with the pipes positioned in profiled particle floorboards with heat-distributing aluminium sheets must be covered with a loadbearing profiled (i.e. tongue/groove) particleboard or plywood of at least 6 mm thickness.

### Room climate

The ambient climate for wood floors should be 35-65% relative humidity (RH) at 20°C. At low RH, fine cracks can occur in the joints between the planks. The best way to control the climate is with an indoor air conditioner for temperature and vapour, especially during wintertime. If given limits for indoor climate parameters such as temperature and relative humidity in the air (RH) at the floor level, exceed or fall short, remarks on evenness, joint openings or board size cannot be reviewed.

The floor can be inspected when the room climate (temperature and RH) has been stable for at least four (4) weeks and has returned to normal values within the limits. Climate variations are natural because of the hygroscopic material properties of wood and any changes will partly or fully revert when the room climate conditions fulfil the requirements above. Underfloor heating causes additional drying of the wood flooring material, which leads to extra shrinking. During wintertime (heating period) the use of humidifiers is recommended.

### Glue down installation

Välinge Hardened Wood Flooring can be installed with full surface bonding using an approved adhesive as an alternative to floating installation. Please note that when installing floors with full surface bonding all floor installation instructions must be followed carefully at all times, as well as the general recommendations and instructions from the adhesive manufacturers must be followed.

### We recommend the following products:

**Bona:** Bona Titan

**Bostik:** Bostik Maxi Bond Parquette

Both these products are an elastic single-component silane-based adhesive for wooden floors.

***If you need a moisture barrier we recommend using the Bona R 590 together with Bona Titan. For Bostik Maxi Bond Parquette please contact Bostik technical support for information.***

The recommendations for adhesives are based on extensive testing by the manufacturers. We recommend that you test the adhesive carefully before installing flooring or contact the adhesive manufacturer's technical customer service if you have any questions.

**⚠ Note!** *We do not assume liability or warranty claims for any losses incurred in using an adhesive system incorrectly.*

- Always glue directly to the subfloor.
- Leave an expansion gap of 8-10 mm between the floor and all walls.
- The tongue and groove must NOT be glued.
- There must be no expansion breaks in the floor regardless of size.
- Do not apply more adhesive than can be "worked" in the course of 10-15 minutes.
- Apply the adhesive with a wide-toothed spatula. The width of the spatula's teeth is important.
- To obtain a good final result it is very important to be precise in the installation of the first rows of planks. Always place the planks in the adhesive in front of the previous row then push and rotate them into place along the side and end of each plank.
- Immediately clean off any adhesive spilled on the wood flooring during installation. Follow the adhesive manufacturer's recommendations.

## Preparations



### Checklist:

- Remove the old skirting boards
- Remove or cut off existing door frames before installing the floor
- Sweep or vacuum subfloor thoroughly
- Measure the room and calculate the number of rows required
- In narrow or long rooms, choose the installation direction to suit the room's proportions, usually lengthwise or in the main direction of light
- Do not open packages before starting installation!
- Inspect the planks before installation and lay aside any with defects
- **Tip:** Dry-lay the first two rows to familiarise yourself with Hardened Wood Flooring



### Tools & Equipment needed:

- Chalk line
- Straight edge
- Safety glasses and an approved dust mask
- Recommended spatula from the adhesive manufacturer
- Wood flooring adhesive
- Expansion wedges
- Sliding mitre saw or jigsaw or a laminate flooring guillotine such as Mega STRATICUT 400
- Metal or diamond saw blade
- Fine pencil
- Ruler
- Set square 45° & 90°

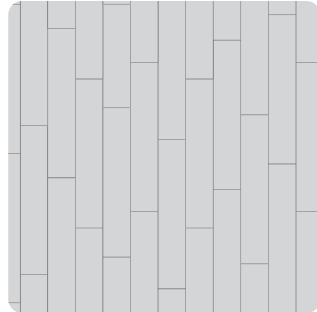
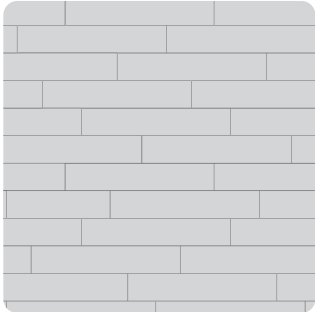

## Installation instructions

Connect the long sides by angling the tongue into the groove (tapping the lower lip will lock it in place). Connect the short ends with the Välinge patented 5G® Fold Down locking system as you lower the plank down.

📺 Please watch: [www.valingeflooring.com/downloads](http://www.valingeflooring.com/downloads)

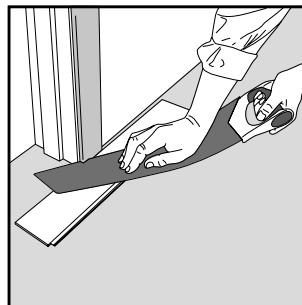

### Tip!

Door frames can be removed and moved up, but cutting them is usually easier. Use a loose plank as a template and saw off the bottom of the frame. Make sure that the planks are not wedged between the subfloor and the frame.

### Step 1 - Layout

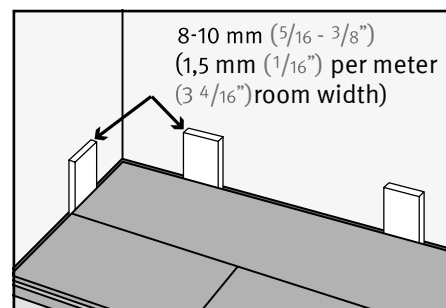
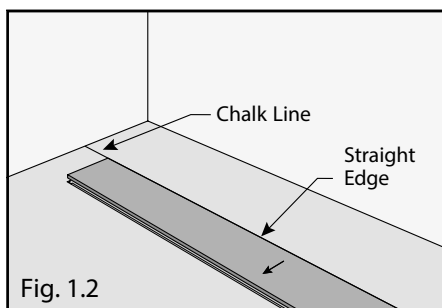
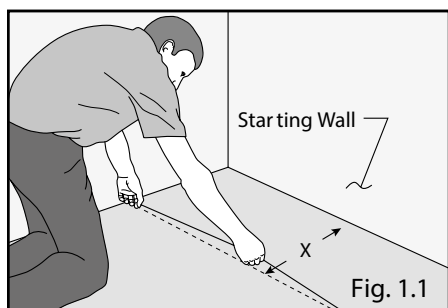

Using the starting wall as reference, snap a chalk line on the subfloor at distance X from the wall as shown in Fig. 1.1. Align the straight edge with the chalk line and secure it to the subfloor.

We recommend a clearance to the wall of min. 8-10 mm (1.5 mm per meter room width).

### Step 2 - Installation

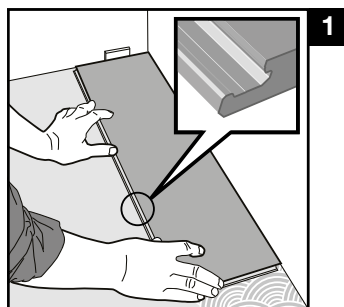

First plank, first row. Start in the left corner with the tongue side facing the wall and the long groove side directly up against the straight edge. Spread enough adhesive to cover one plank width. Use only as much adhesive as can be used during the manufacturer's maximum recommended time for keeping the container open.

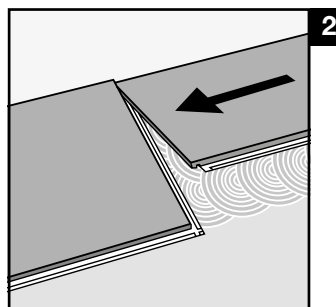

Second plank, first row. Line up the plank gently and tightly to the short end of the previous plank.

## Glue Down Installation Instructions

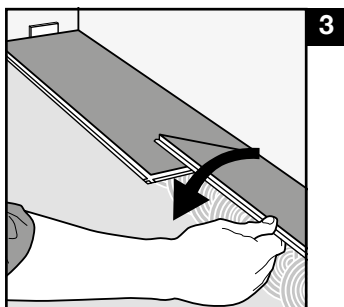

Lower the plank down in a single movement. Make sure the planks are tight against each other. Press down the plank.

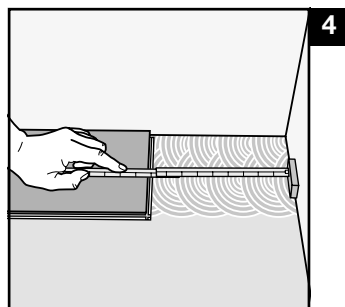

At the end of the first row, put a wedge to the wall and measure the length of the last plank to fit.

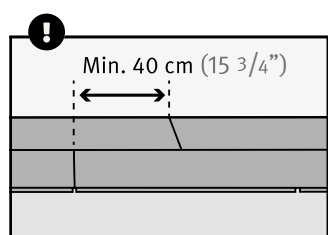
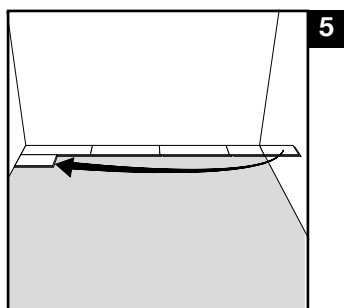

Start the second row with the offcut from the first row.

**Note!** There must be at least 40 cm between the short end joints of the planks.

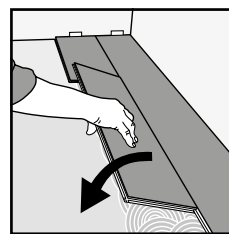
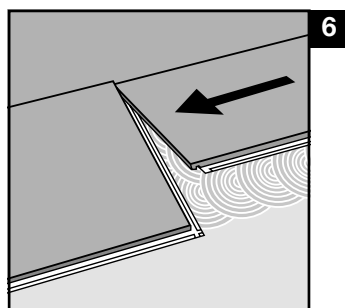

Second plank, second row. Place the plank gently and tightly to the short end of the previous plank. Lower the plank down in a single movement. Make sure the planks are tight against each other. Press down the plank.

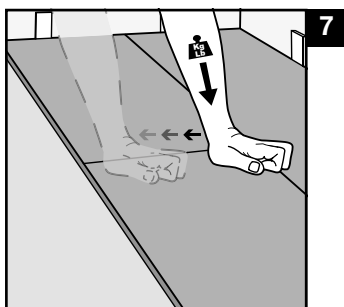

**Note!** Ensure that the short end is connected.

### Note!

- After the first 2-3 rows have been installed, ensure the expansion space between planks and walls is aligned securely
- If recommended by the adhesive manufacturer, roll the flooring with a 45 kg. roller to ensure contact between the flooring and subfloor. Place a weight (e.g. unopened cartons) along the perimeters until the adhesive sets
- Remove the straight edge



## Glue Down Installation Instructions

### Step 3 - Subsequent rows

Once the starting rows are firmly in place, apply adhesive using the “wet lay” method. Do not apply more adhesive than can be used within the opening time of the adhesive. Immediately place the flooring in “wet” adhesive and proceed with installation.

- Start each row with the cut-off end of the last plank of the previous row.
- Ensure there is at least 40 cm between the plank joints at the short ends.
- Hardened Wood Flooring can be laid from both directions according to need.

#### Tip!

- After the first three rows are laid, have one installer work on installing the flooring while others spread adhesive and cut planks as needed
- Installing Hardened Wood Flooring is easier when you work from the direction of already installed flooring, as shown in Fig. 3.1
- Working in this manner lessens the chance of accidentally transferring adhesive onto the flooring surface, thereby reducing clean-up time

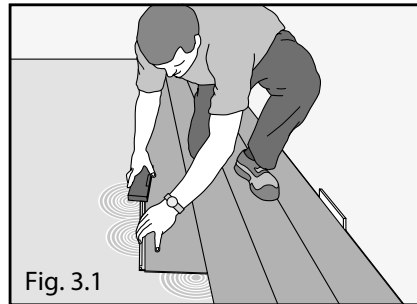
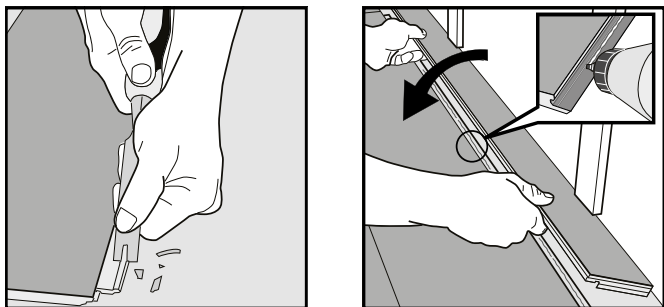

Fig. 3.1

## Glue Down Installation Instructions

### When angling is not possible



Remove the locking element/hook according to the picture. Use white PVAc glue to connect the planks. Position wedges between the glued plank and the wall.

### Installation around pipes

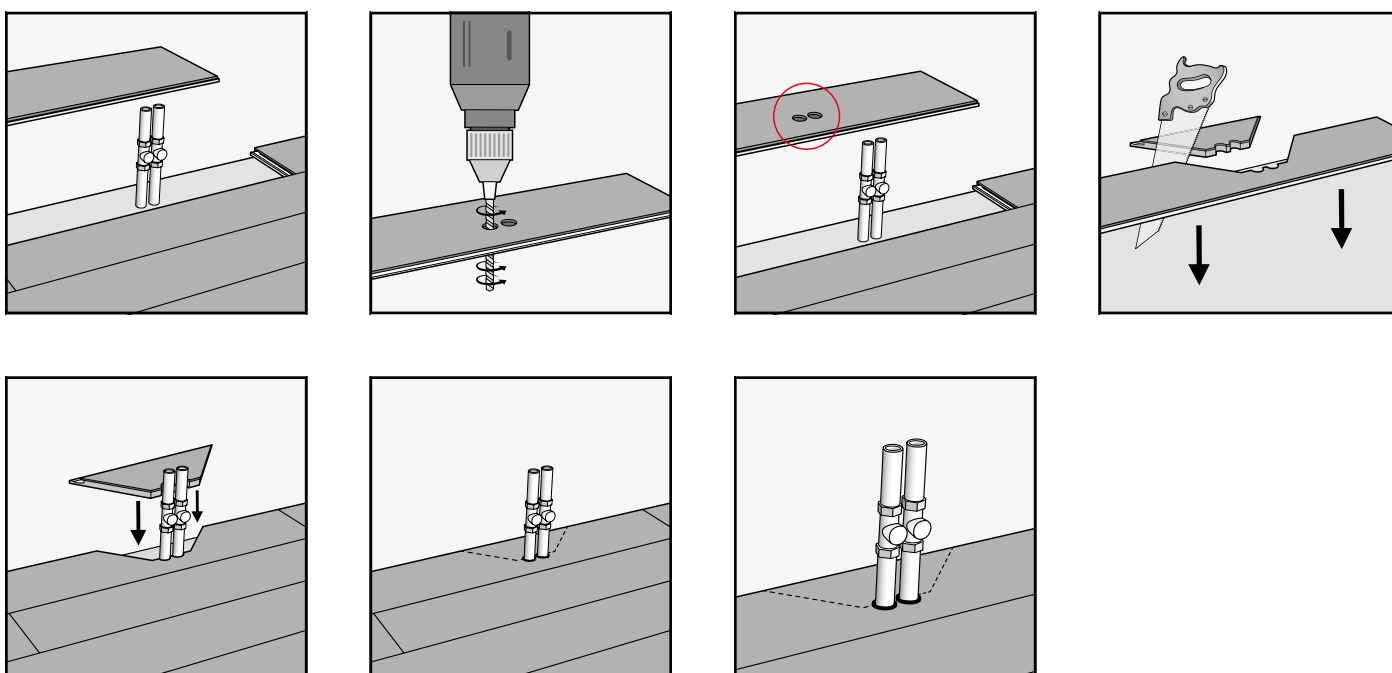

Mark the centre point of the pipes on the plank. Drill holes 20 mm bigger than the pipe's diameter (if gap distance selected is 10 mm). Cut according to the picture. Fix with white glue and replace the floor pieces. Cover the holes with pipe collars or fill with a joint sealer.

## After installation

- Do not lay rugs or carpets on the floor during the first months after installation. Areas beneath a rug will show up lighter than the rest of the wood floor, which will darken slightly when exposed to sunlight.
- Protective felt pads are recommended under furniture legs and protective carpets under castor chairs with hard wheels.
- Always use protective entrance carpets.

## Installation treatment

### Pre-lacquered floor:

Pre-lacquered hardened wood floors do not need any surface treatment after installation. But we recommend cleaning the floor before using it. Use a hardwood floor cleaner for lacquered wood floors (e.g. Bona Hardwood Floor Cleaner).

**ⓘ Note!** Use detergent specially formulated for UV Acrylic Wear Layer hardwood floors. Normal soap may form a fatty coating on the surface which makes the floor more difficult to clean.

### Pre-oiled floor:

#### Domestic areas

In domestic areas pre-oiled hardened wood floors do not need any surface treatment after installation. But we recommend cleaning the floor before using it. Use a hardwood floor cleaner for oiled wood floors (e.g. Bona Hardwood Floor Cleaner).

**ⓘ Note!** Use detergent specially formulated for oiled wood floors. Normal soap may form a fatty coating on the surface which makes the floor more difficult to clean.

#### Commercial premises

**ⓘ Note!** In commercial premises we recommend that the first periodic maintenance should be performed immediately after installation. Pre-oiled hardened wood floors installed in commercial premises must be given additional surface treatment to meet the requirements to which they are exposed.

Clean the floor of any dust from installation before starting the oil treatment. Use a hardwood floor cleaner for oiled wood floors (e.g. Bona Hardwood Floor Cleaner).

In commercial premises we recommend using hardwax oil from Osmo.

## Daily cleaning

For daily cleaning use mainly dry methods, such as a vacuum cleaner, dust mop or microfibre mop. Stains/dirt can easily be removed by using a magic melamine sponge.

## Regular cleaning

Clean the surface with a microfibre cleaning pad and a hardwood floor cleaner for lacquered wood floors or oiled wood floors (e.g. Bona Hardwood Floor Cleaner).

## Maintenance

### Pre-lacquered floor:

If necessary, a hardwood floor refresher for lacquered wooden floors (e.g. Bona Hardwood Floor Refresher) can be used to freshen up the surface and remove any surface scratches.

A refresher restores the surface of well-worn lacquer and gives a protective layer that simplifies cleaning and maintenance. A refresh is not a substitute for refinishing.

**ⓘ Note!** Using a hardwood floor refresher increases the glossiness on lacquered floors. The more layers you put on, the higher the glossiness level. This is more evident on matt lacquered floors. The floor to be treated should be clean and free from polish, wax and any grease stains.

### Pre-oiled floor:

Pre-oiled hardened wood floors need to be maintained regularly.

For maintenance treatment we recommend using maintenance oil or hardwax oil from Osmo.



woodura®



2G®, 5G® and Woodura® are trademarks for patented technologies – invented, registered and owned by Välinge Innovation AB. Use of the marks or technologies is under licence.